

APPLICATION

Designed for interior and exterior applications that require an access opening that will blend in with the surrounding floor material

FEATURES

- Recessed 1/8" to accommodate carpeting and vinyl tile
- Door panel is equipped with a flush aluminum drop handle and an automatic hold open arm

SPECIFICATIONS

MATERIAL: Aluminum door and frame

DOOR: 1/4" smooth aluminum plate reinforced for live load of 150 lb/sq. ft. Extruded edging is welded to door panel, providing a 1/8" recess

FRAME: Angle frame fabricated from aluminum extrusion with integral 1" anchor flange on three sides and welded anchor straps on the hinge side

HINGE: Extruded aluminum hinges are welded to inside of door panel and pivot on stainless steel pins. Hold open arm with red Vinyl grip allow automatic opening

OPENING DEVICE: Door panel to open to 90 degrees, locking door in open position, and allowing for easy control when closing door panel. Stainless steel torsion bars provide lift assistance. Available with electrical actuators, operated by wall mounted push button switch, and remote control

STANDARD LATCH: Stainless steel slamlock with a fixed inside handle, removable outside handle, and removable threaded plug

FINISH: Mill finish with bituminous coating applied to exterior of frame



For a complete list of options visit www.AcudorAccessPanels.com



SKU: **FT-8040**

RECESSED FLOOR DOOR

FOR VINYL TILE/CARPET

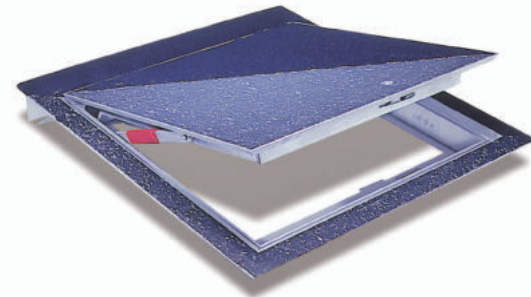

DIMENSIONS AND APPEARANCE

>> CLICK TO VIEW ADDITIONAL DETAILS AND PRICING <<

STANDARD SIZES:

DOOR SIZE W x H INCHES (MM)	WEIGHT	
	LBS	KG
24 x 24 (609 x 609)	25	11
24 x 30 (609 x 762)	54	24
24 x 36 (609 x 914)	62	28
30 x 30 (762 x 762)	74	33
30 x 36 (762 x 914)	82	37
36 x 36 (914 x 914)	85	38
42 x 42 (1066 x 1066)	90	40
*48 x 48 (1220 x 1220)	155	71
*48 x 72 (1220 x 1829)	220	100
*60 x 60 (1524 x 1524)	225	102

* DOUBLE LEAF

For detailed specifications see submittal sheet

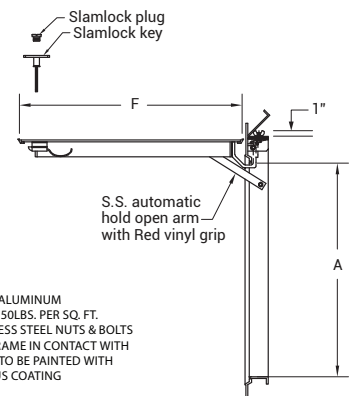
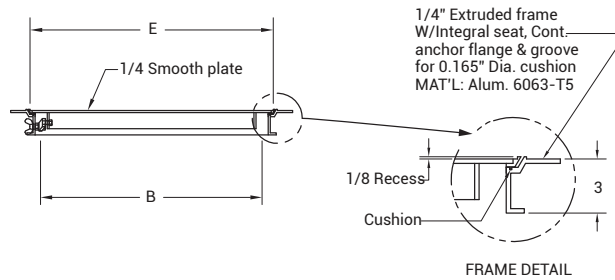
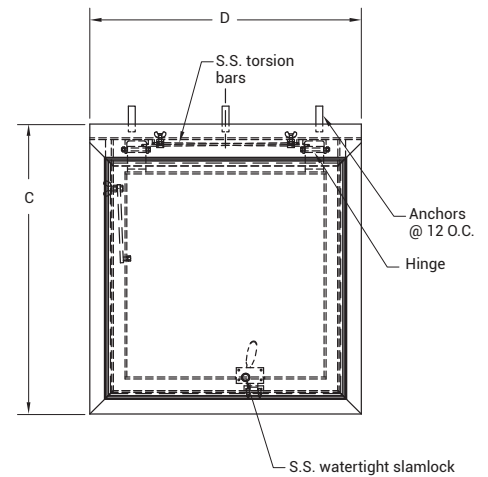

- NOTES:
- MATERIAL: ALUMINUM
 - LOADING: 150LBS. PER SQ. FT.
 - 316 STAINLESS STEEL NUTS & BOLTS
 - AREA OF FRAME IN CONTACT WITH CONCRETE TO BE PAINTED WITH BITUMINOUS COATING

Proprietary property of Acudor Products, Inc., sold and distributed with proper authorization

PROJECT DATA

Custom Sizes Available - Fast!

PROJECT NAME :	QTY	W	H	OPTIONS
ARCHITECT :				
DEALER :				
CONTRACTOR :				
LOCATION :	SPECIAL INSTRUCTIONS :			
DATE :	SUBMITTAL APPROVAL : (signature or stamp)			
TAGGING INSTRUCTIONS :				

Scan or Click



To view Pricing and Additional Product Info.



TELEPHONE:
1-888-622-8367
FAX:
1-888-626-2907



PO BOX 4668
PMB 76520
NEW YORK,
NEW YORK 10163-4668
US



WEBSITE:
www.AcudorAccessPanels.com
E-MAIL:
info@AcudorAccessPanels.com

FT-8040

1/8" RECESSED FOR VINYL TILE/CARPET - SINGLE LEAF

NOMINAL SIZE inches (mm)	CLEAR OPENING		OVERALL SIZE		RECEIVING TILE AREA		WEIGHT lbs. (kg)
	A	B	C	D	E	F	
24 x 24 (609 x 609)	22.75 (578)	22.75 (578)	31.125 (793)	28.75 (730)	24.00 (609)	24.00 (609)	25 (11)
24 x 30 (609 x 762)	22.75 (578)	28.75 (730)	31.125 (793)	34.75 (882)	30.00 (762)	24.00 (609)	54 (24)
24 x 36 (609 x 914)	22.75 (578)	34.75 (882)	31.125 (793)	40.75 (1035)	36.00 (914)	24.00 (609)	62 (28)
30 x 30 (762 x 762)	28.75 (730)	28.75 (730)	37.125 (942)	34.75 (882)	30.00 (762)	30.00 (762)	74 (33)
30 x 36 (762 x 914)	28.75 (730)	34.75 (882)	37.125 (942)	40.75 (1035)	36.00 (914)	30.00 (762)	82 (37)
36 x 36 (914 x 914)	34.75 (882)	34.75 (882)	43.125 (1092)	40.75 (1035)	36.00 (914)	36.00 (914)	85 (38)
42 x 42 (1066 x 1066)	40.75 (1035)	40.75 (1035)	49.125 (1247)	46.75 (1187)	42.00 (1066)	42.00 (1066)	90 (40)

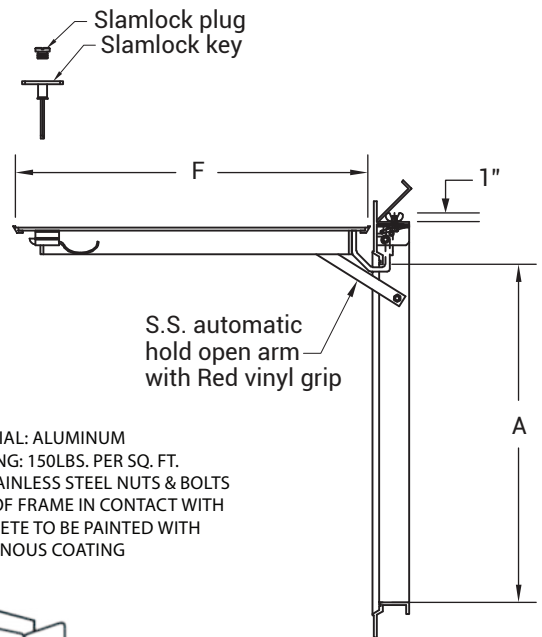
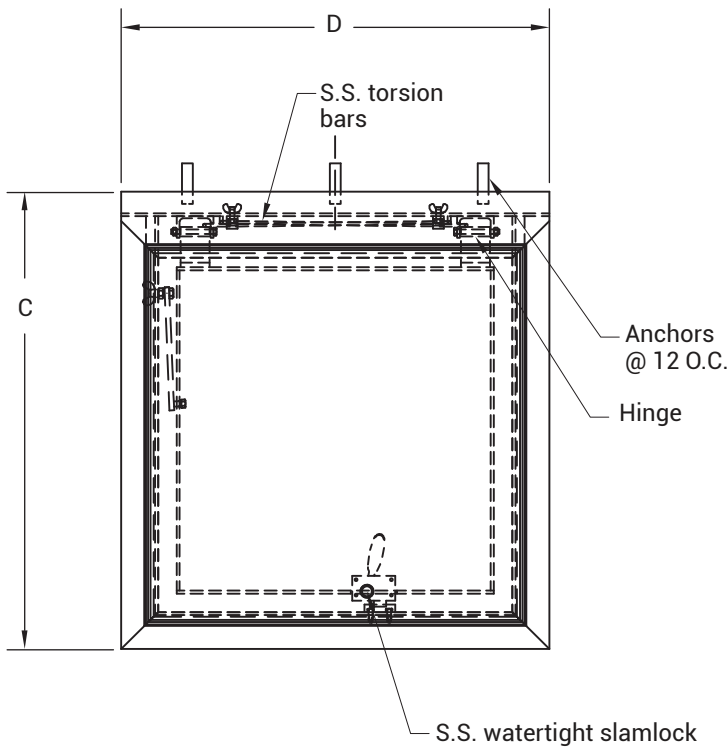

- NOTES:
- MATERIAL: ALUMINUM
 - LOADING: 150LBS. PER SQ. FT.
 - 316 STAINLESS STEEL NUTS & BOLTS
 - AREA OF FRAME IN CONTACT WITH CONCRETE TO BE PAINTED WITH BITUMINOUS COATING

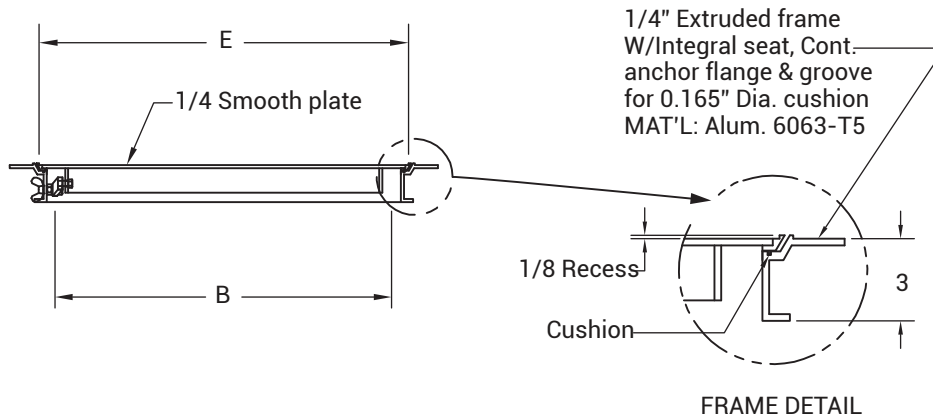

FT-8040

1/8" RECESSED FOR VINYL TILE/CARPET - DOUBLE LEAF

NOMINAL SIZE inches (mm)	CLEAR OPENING		OVERALL SIZE		RECEIVING TILE AREA		WEIGHT lbs. (kg)
	A	B	C	D	E	F	
48 x 48 (1220 x 1220)	47 (1193)	46.75 (1187)	58.00 (1473)	52.75 (1339)	48.00 (1220)	24.00 (609)	155 (71)
48 x 72 (1220 x 1829)	69 (1752)	46.75 (1187)	81.50 (2070)	52.75 (1339)	48.00 (1220)	35.75 (908)	220 (100)
60 x 60 (1524 x 1524)	59 (1498)	58.75 (1492)	70.00 (1778)	64.75 (1644)	60.00 (1524)	30.00 (762)	225 (102)

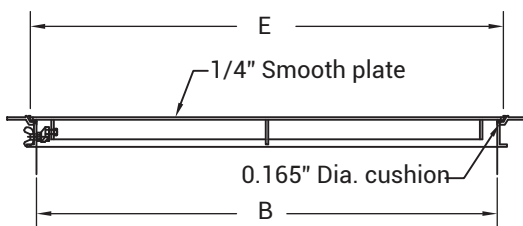
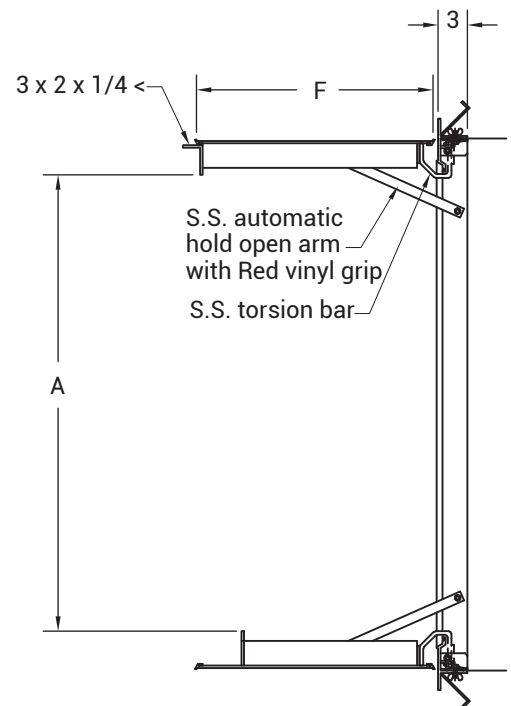
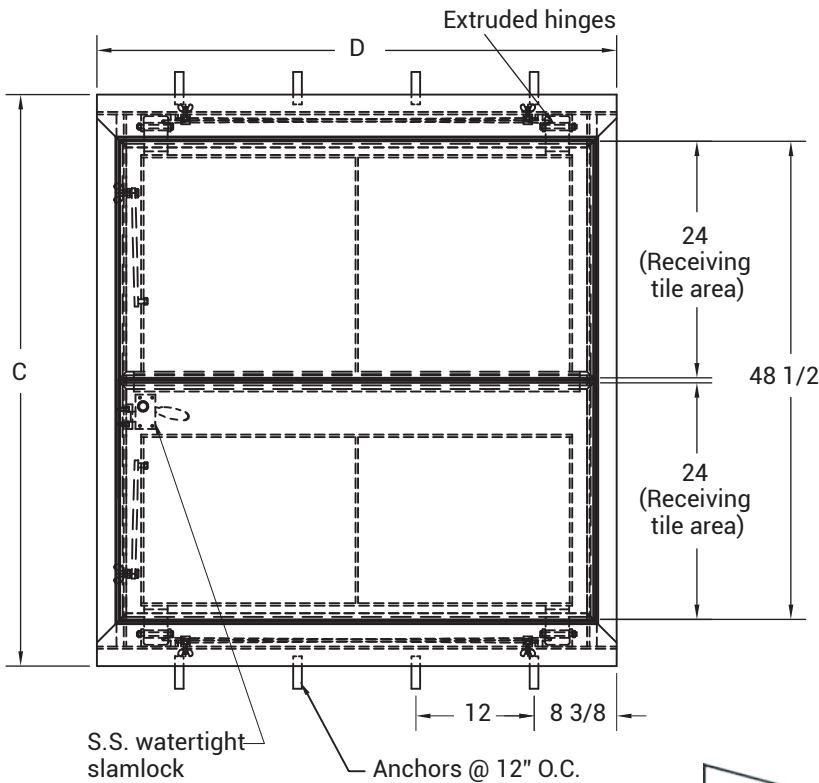

- NOTES:
- MATERIAL: ALUMINUM
 - LOADING: 150LBS. PER SQ. FT.
 - 316 STAINLESS STEEL NUTS & BOLTS
 - AREA OF FRAME IN CONTACT WITH CONCRETE TO BE PAINTED WITH BITUMINOUS COATING

