

APPLICATION

Designed for interior and exterior applications that require an access opening that will blend in with the surrounding floor material

FEATURES

- Recessed 1" to accommodate ceramic tile/concrete flooring
- Door panel is equipped with a flush aluminum drop handle and an automatic hold open arm

SPECIFICATIONS

MATERIAL: Aluminum door and frame; stainless steel hinges and hardware

DOOR: 1/4" smooth aluminum plate reinforced for live load of 300 lb/sq. ft. Extruded edging is welded to door panel, providing a 1" recess

FRAME: Channel frame fabricated from aluminum extrusion with 1 1/2" drainage coupling and integral 1" anchor flange

HINGE: Stainless steel continuous piano hinge

OPENING DEVICE: Automatic Hold-Open Arm with red vinyl grip allows door panel to open to 90 degrees, locking door in open position, and allowing for easy control when closing door panel. Stainless Steel Open Compression Springs provide lift assist. Available with electrical actuators, operated by wall mounted push button switch, and remote control

STANDARD LATCH: Stainless steel slam lock with a fixed inside handle, removable outside handle, and removable threaded plug

FINISH: Mill finish with bituminous coating applied to exterior of frame

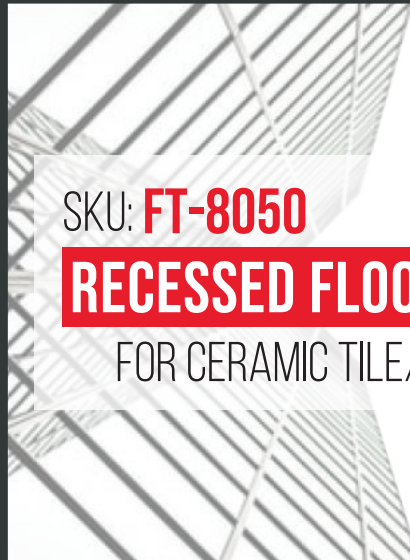

SKU: **FT-8050**

RECESSED FLOOR DOOR

FOR CERAMIC TILE/CONCRETE



DIMENSIONS AND APPEARANCE

>> CLICK TO VIEW ADDITIONAL DETAILS AND PRICING <<

STANDARD SIZES:

| DOOR SIZE W x H INCHES (MM) | WEIGHT | |
|--------------------------------|--------|-----|
| | LBS | KG |
| 24 x 24 (610 x 610) | 70 | 32 |
| 24 x 30 (610 x 762) | 80 | 37 |
| 24 x 36 (610 x 914) | 90 | 41 |
| 30 x 30 (762 x 762) | 110 | 50 |
| 30 x 36 (762 x 914) | 100 | 45 |
| 36 x 36 (914 x 914) | 115 | 52 |
| 42 x 42 (1067 x 1067) | 140 | 64 |
| *48 x 48 (1220 x 1220) | 195 | 89 |
| *48 x 72 (1220 x 1829) | 265 | 120 |
| *60 x 60 (1524 x 1524) | 275 | 125 |

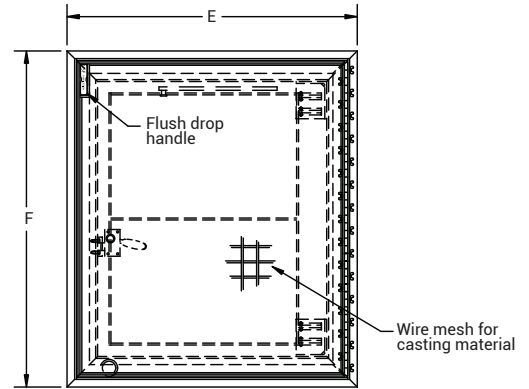

* DOUBLE LEAF For detailed specifications see submittal sheet

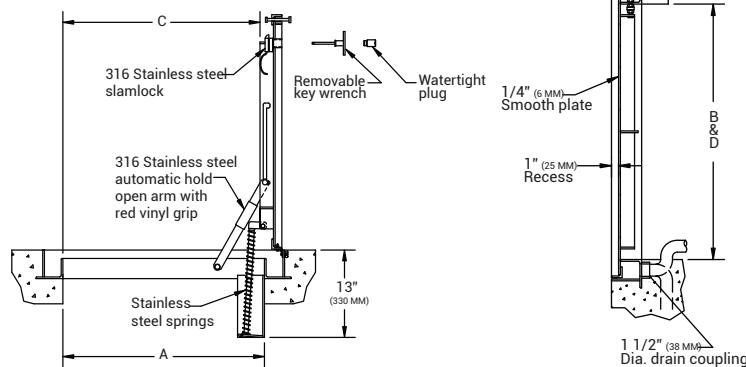

- NOTES:**
- MATERIAL: ALUMINUM WITH SPRINGS, 316 STAINLESS STEEL NUTS & BOLTS, SLAMLOCK, HINGES AND HOLD OPEN ARM.
 - LOADING: 300 LBS. PER SQ. FOOT (1464 KG. PER SQ. M)
 - BITUMINOUS COATING IS APPLIED TO AREA OF FRAME IN CONTACT WITH CONCRETE.

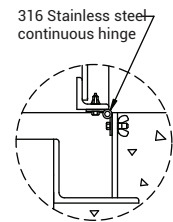

Proprietary property of Acudor Products, Inc., sold and distributed with proper authorization



For a complete list of options visit www.AcudorAccessPanels.com

PROJECT DATA

Custom Sizes Available - Fast!

| PROJECT NAME : | QTY | W | H | OPTIONS |
|------------------------|--|---|---|---------|
| ARCHITECT : | | | | |
| DEALER : | | | | |
| CONTRACTOR : | | | | |
| LOCATION : | SPECIAL INSTRUCTIONS : | | | |
| DATE : | | | | |
| TAGGING INSTRUCTIONS : | SUBMITTAL APPROVAL : (signature or stamp) | | | |

Scan or Click



To view Pricing and Additional Product Info.



TELEPHONE:
1-888-622-8367
FAX:
1-888-626-2907



PO BOX 4668
PMB 76520
NEW YORK,
NEW YORK 10163-4668
US



WEBSITE:
www.AcudorAccessPanels.com
E-MAIL:
info@AcudorAccessPanels.com

FT-8050

1" RECESSED FOR CERAMIC TILE/ CONCRETE FLOOR DOOR - SINGLE LEAF

| NOMINAL DOOR SIZE | FRAME OPENING | | CLEAR OPENING | | OVERALL SIZE | | WEIGHT |
|-----------------------|---------------|------------|---------------|------------|--------------|------------|------------|
| | in. (mm) | A in. (mm) | B in. (mm) | C in. (mm) | D in. (mm) | E in. (mm) | F in. (mm) |
| 24 x 24 (610 x 610) | 24 (610) | 24 (610) | 23 (584) | 24 (610) | 32 (813) | 32 (813) | 70 (32) |
| 24 x 30 (610 x 762) | 24 (610) | 30 (762) | 23 (584) | 30 (762) | 32 (813) | 38 (965) | 80 (37) |
| 24 x 36 (610 x 914) | 24 (610) | 36 (914) | 23 (584) | 36 (914) | 32 (813) | 44 (1118) | 90 (41) |
| 30 x 30 (762 x 762) | 30 (762) | 30 (762) | 28 (711) | 30 (762) | 38 (965) | 38 (965) | 110 (50) |
| 30 x 36 (762 x 914) | 30 (762) | 36 (762) | 28 (711) | 36 (762) | 38 (965) | 44 (1118) | 100 (45) |
| 36 x 36 (914 x 914) | 36 (914) | 36 (762) | 34 (864) | 36 (762) | 44 (1118) | 44 (1118) | 115 (52) |
| 42 x 42 (1067 x 1067) | 42 (1067) | 42 (1067) | 40 (1016) | 42 (1067) | 50 (1270) | 50 (1270) | 140 (64) |

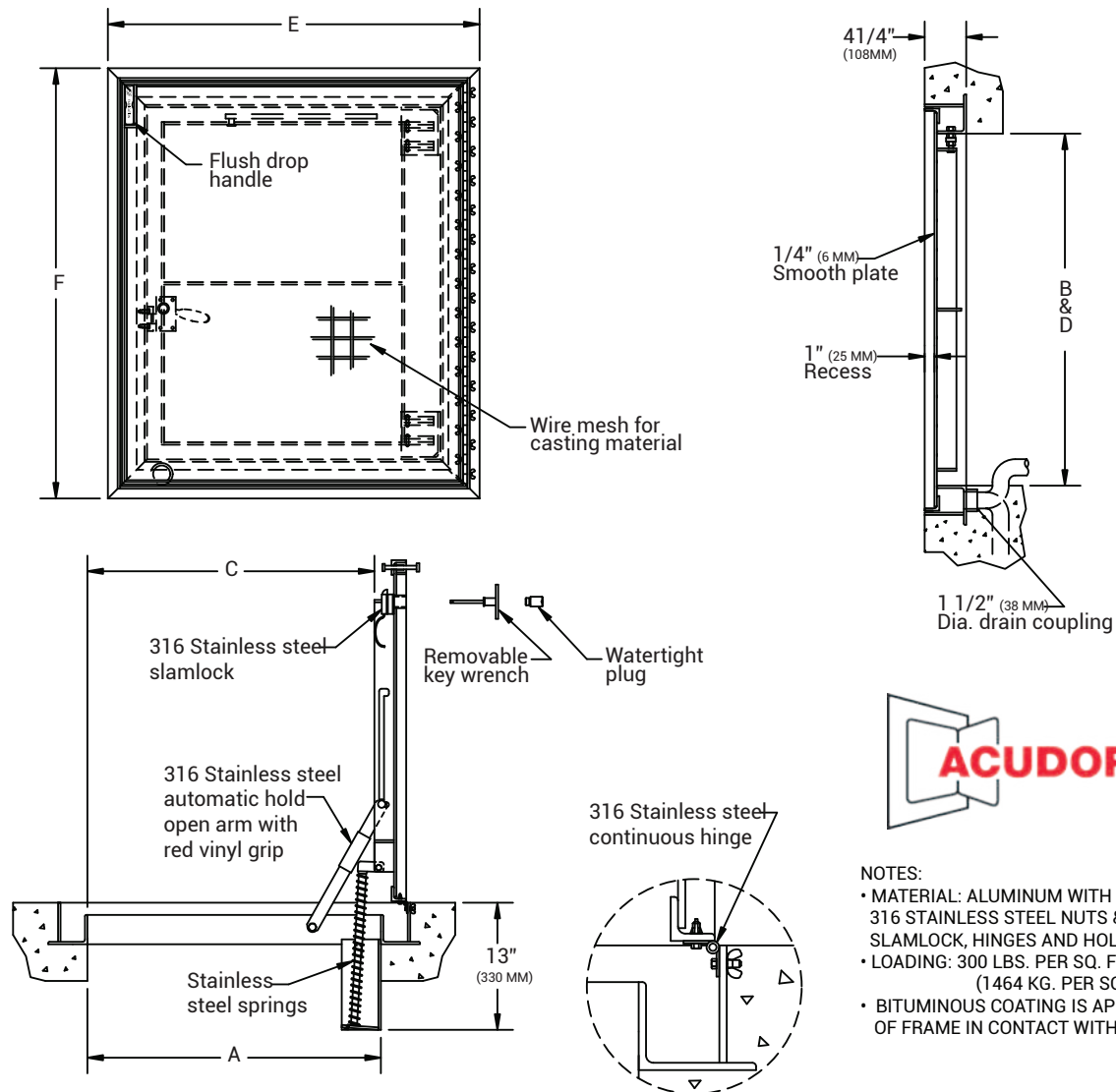

- NOTES:
- MATERIAL: ALUMINUM WITH SPRINGS, 316 STAINLESS STEEL NUTS & BOLTS, SLAMLOCK, HINGES AND HOLD OPEN ARM.
 - LOADING: 300 LBS. PER SQ. FOOT (1464 KG. PER SQ. M)
 - BITUMINOUS COATING IS APPLIED TO AREA OF FRAME IN CONTACT WITH CONCRETE.

FT-8050

1" RECESSED FOR CERAMIC TILE/ CONCRETE FLOOR DOOR - DOUBLE LEAF

| NOMINAL DOOR SIZE | FRAME OPENING | | CLEAR OPENING | | OVERALL SIZE | | WEIGHT |
|-----------------------|---------------|------------|---------------|------------|--------------|------------|-----------|
| in. (mm) | A in. (mm) | B in. (mm) | C in. (mm) | D in. (mm) | E in. (mm) | F in. (mm) | LBS. (KG) |
| 48 x 48 (1220 x 1220) | 48 (1220) | 48 (1220) | 47 (1193) | 48 (1220) | 56 (1422) | 56 (1422) | 195 (89) |
| 48 x 72 (1220 x 1829) | 48 (1220) | 72 (1828) | 47 (1193) | 72 (1828) | 56 (1422) | 80 (2032) | 265 (120) |
| 60 x 60 (1524 x 1524) | 60 (1524) | 60 (1524) | 59 (1498) | 60 (1524) | 68 (1727) | 68 (1727) | 275 (125) |

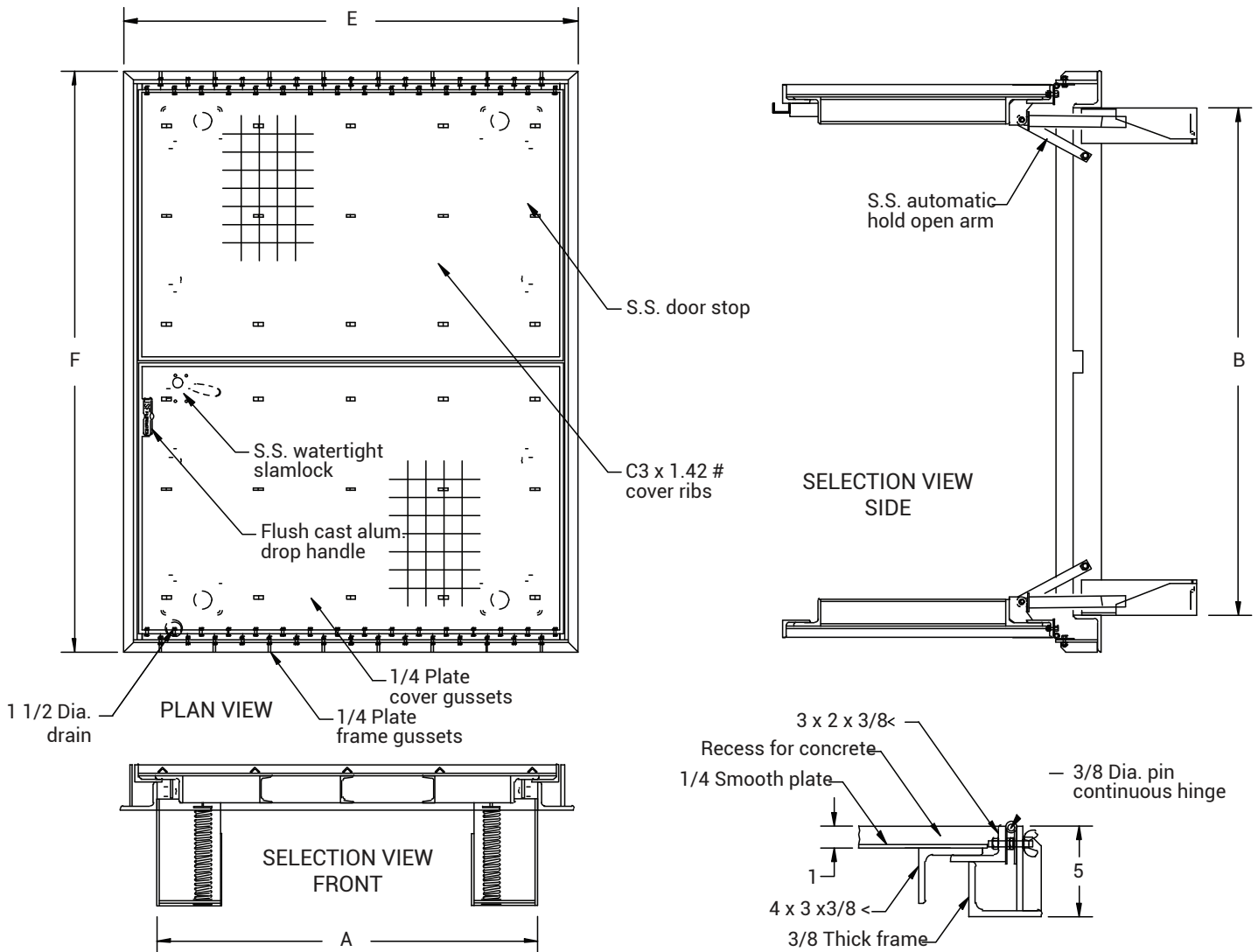

- NOTES:
- MATERIAL: ALUMINUM
 - LOADING: 300 LBS. PER SQ. FT.
 - 316 STAINLESS STEEL BOLTS
HINGES AND HOLD OPEN ARM